



DAQICONCEPT CHIRP
CP01



USER MANUAL
EN – ENGLISH



- Use a 1-port 5V1A/2A USB adaptor.
- DAQICONCEPT CHIRP must only be installed and operated in dry, indoor spaces. Do not install DAQICONCEPT CHIRP in locations with high levels of humidity, e.g. in the bathroom.
- Never touch the plug and cable with wet hands due to the risk of electrical shock.
- Do not expose DAQICONCEPT CHIRP to extreme temperatures, direct sunlight, moisture, strong vibration or high mechanical stress. The safe operating temperature ranges between 50F/10° C and 95F/35° C.
- DAQICONCEPT CHIRP is made of solid material. Ensure that the device is positioned securely to prevent injury or damage to surfaces and objects from a fall. Do not drop DAQICONCEPT CHIRP on the floor, hit it hard or expose it to other heavy shocks.
- This device is not intended to be used by persons (including children) with restricted physical, sensory or mental abilities or lacking experience and/or knowledge, unless they are supervised by a person responsible for their safety or have received instructions on how to use the device by that person.
- This is not a toy. Children should be supervised to ensure they do not play with DAQICONCEPT CHIRP.
- Do not look directly at lighted bird belly.
- Do not cover DAQICONCEPT CHIRP with cloth or plastic bag to avoid overheating damage.

OVERVIEW

DAQICONCEPT CHIRP is an alarm clock that blends decoration lighting with traditional craftsmanship. A welcome departure from the synthesized sounds from a mobile device or a regular alarm clock, DAQICONCEPT CHIRP awakens you with gentle light and the blissful sounds of nature. Wake up feeling refreshed, energized and ready to start each new day.

SPECIFICATION

LED Color Temperature :
2700K

Dimension :
210 (h) x 91 (w) x 91(l) mm

Weight :
400g

Material :
porcelain bird cover /
marble base / metal /
plastic

Power by :
5V1A USB charger



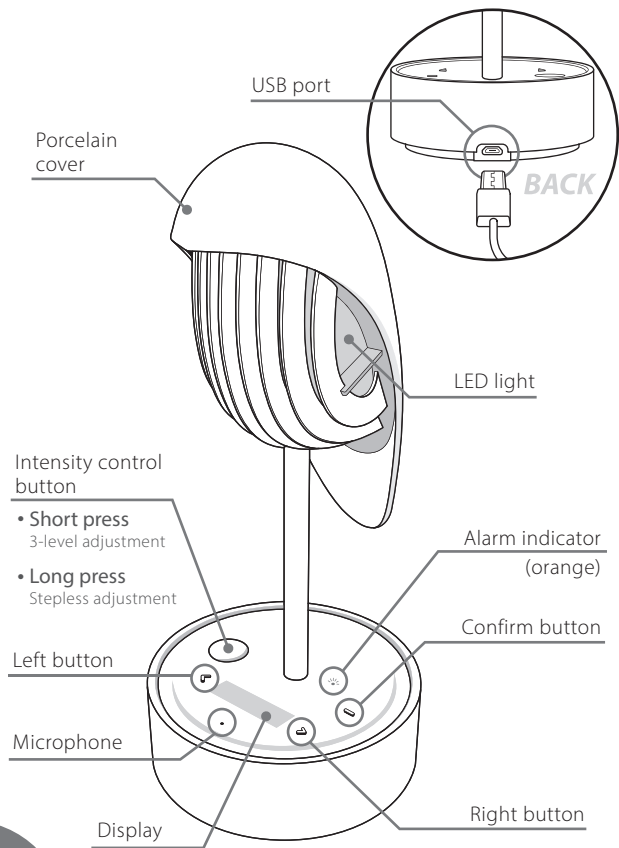

OPERATIONS DISPLAY MENU

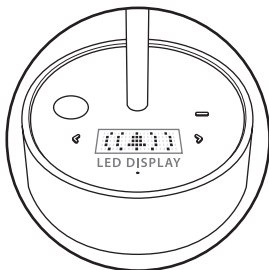

ALARM
setting



Alarm & light



Alarm only



SLEEP
mode



30 minutes
countdown



60 minutes
countdown



VOLUME
control



Volume 1



Volume 7



NATURE
sound



Nature Sound 1



Nature Sound 2



Nature Sound 3

OPERATIONS

Menu navigation

To wake up the display, touch the bottom of the device to show time, and click < or > to select a setting, press confirm button to operate

Wake up CHIRP to show time

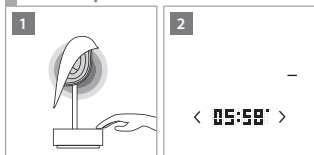

Click right or left button



Navigational details

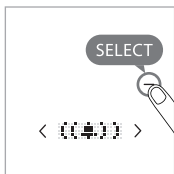

Once a variable is selected it either navigates you automatically to the following step, or back up to the general menu.



The round button allows you to enlighten the light and adjust intensity.

Setting Clock time

To set the clock time, choose between a 12-hour and a 24-hour clock and then adjust the time

Choose 12HR / 24HR

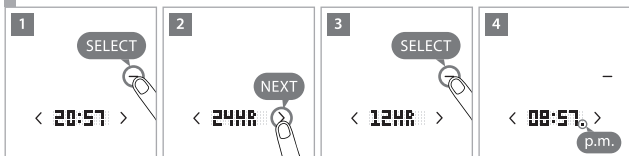

Adjust the time

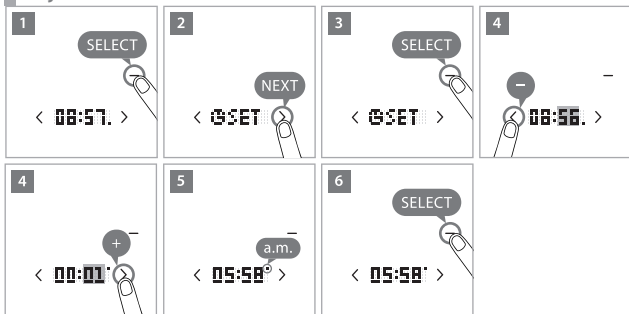

When chosen 12hr mode, the point location indicates if the time is a.m. or p.m.

Setting Alarm

Choose with light mode or sound only mode

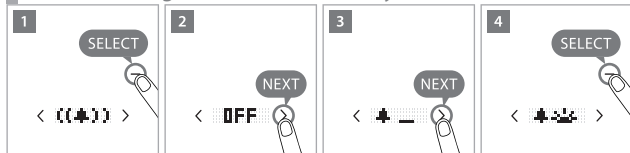

Adjust the alarm time



Adjust the alarm volume

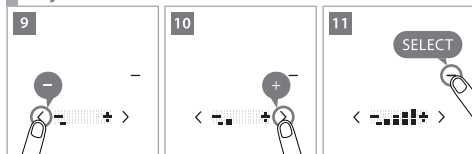

alarm indicator enlightens in orange once the alarm setting is done.



Snooze

When the alarm sound is played at the set time, you can tap on any button of the device to snooze for a while. The light stays on, but the alarm sound stops, after 10 minutes, the alarm sound is automatically played again.

Snooze 10 minutes

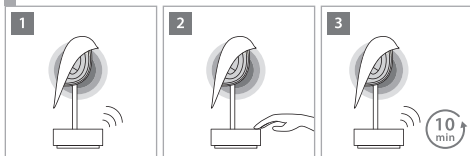

Switch off the alarm

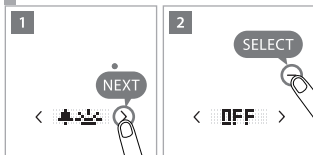

or

Switch off the alarm

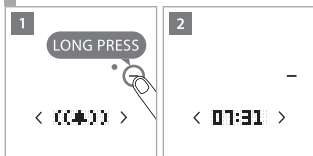

NOTICE

If you do not snooze or switch off the alarm, the alarm will turn off automatically after 15 minutes.

Play Nature Sound

Choose one nature sound, confirm with the select button and the sound keeps on playing.

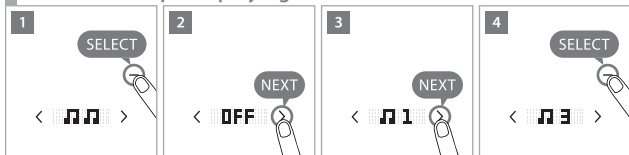

Adjust nature sound volume

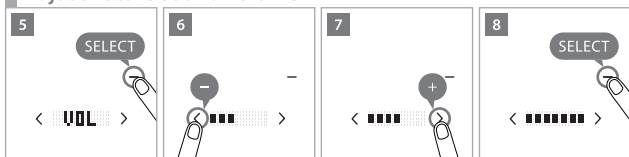

To turn off the nature sound, enter , and select "off".



or

Long press

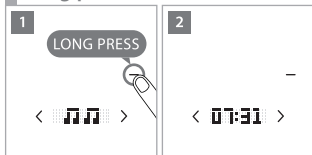

Sleep mode

To use the sleep function you need to select a timer.

- Press the sleep mode and choose 30 or 60 minutes count down, then press confirm.
- After 30 (or 60) minutes, the nature sound will stop and the light off.

Select 30 or 60 minutes count down

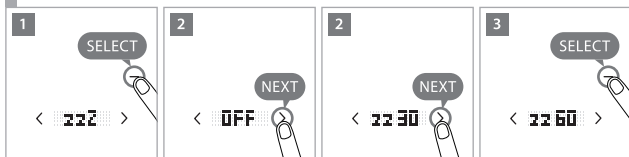

Synchronize by phone App DAQIChirp

Time, alarm and additional nature sound can be synchronized by phone App “DAQIChirp”. The selected data is transmitted via audio transmission to DAQICONCEPT CHIRP.

NOTICE

A successful transmission can be only guaranteed while the speaker of the phone is facing the microphone of DAQICONCEPT CHIRP.

Microphone

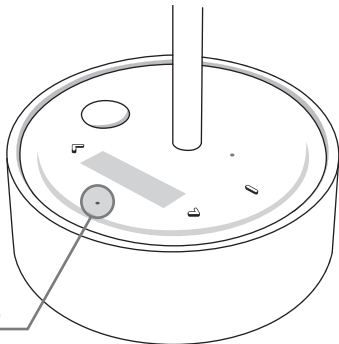

Find more information on : www.daqiconcept.com



HANDBUCH
DE – DEUTSCH



- Verwenden Sie einen 1-port 5V1A/2A USB-Adapter.
- DAQICONCEPT CHIRP darf nur in trockenen Innenräumen installiert und betrieben werden. Installieren Sie DAQICONCEPT CHIRP nicht an Orten mit hoher Luftfeuchtigkeit, z.B. im Badezimmer.
- Fassen Sie den Stecker und das Kabel niemals mit nassen Händen an, da die Gefahr eines Stromschlags besteht.
- Setzen Sie DAQICONCEPT CHIRP keinen extremen Temperaturen, direkter Sonneneinstrahlung, Feuchtigkeit, starken Vibrationen oder hohen mechanischen Belastungen aus. Die sichere Betriebstemperatur liegt zwischen 10° C und 35° C.
- DAQICONCEPT CHIRP besteht aus festem Material. Stellen Sie sicher, dass das Gerät sicher positioniert ist, um Verletzungen oder Schäden an Oberflächen und Gegenständen durch einen Sturz zu vermeiden. Lassen Sie DAQICONCEPT CHIRP nicht auf den Boden fallen, schlagen Sie nicht darauf und setzen Sie ihn keinen anderen starken Stößen aus.
- Dieses Gerät darf nicht von Personen (einschließlich Kindern) mit eingeschränkten körperlichen, sensorischen oder geistigen Fähigkeiten oder mangelnder Erfahrung und/oder Kenntnis verwendet werden, es sei denn, sie werden von einer für ihre Sicherheit verantwortlichen Person beaufsichtigt oder haben Anweisungen zum Gebrauch von dieser Person erhalten.
- Dies ist kein Spielzeug. Kinder sollten beaufsichtigt werden, um sicherzustellen, dass sie nicht mit DAQICONCEPT CHIRP spielen.
- Schauen Sie nicht direkt auf den beleuchteten Vogelbauch.
- Decken Sie DAQICONCEPT CHIRP nicht mit einem Tuch oder einer Plastiktüte ab, um Überhitzungsschäden zu vermeiden

ÜBERSICHT

DAQICONCEPT CHIRP ist ein Wecker, der Dekorationsbeleuchtung mit traditioneller Handwerkskunst verbindet. Eine willkommene Abkehr von den synthetisierten Klängen von mobilen Geräten oder normalen Wecker, DAQICONCEPT CHIRP weckt Sie mit sanftem Licht und den wunderbaren Klängen der Natur. Wachen Sie erfrischt, energiegeladen und bereit auf, um jeden neuen Tag zu beginnen.

SPEZIFIKATIONEN

LED-Farbtemperatur :
2700K

Abmessungen :
210 (h) x 91 (b) x 91(l) mm

Gewicht :
400g

Material:
Porzellan Vogelperspektive /
Marmorsockel / Metall /
Kunststoff

Strom durch :
5V1A USB-Ladegerät

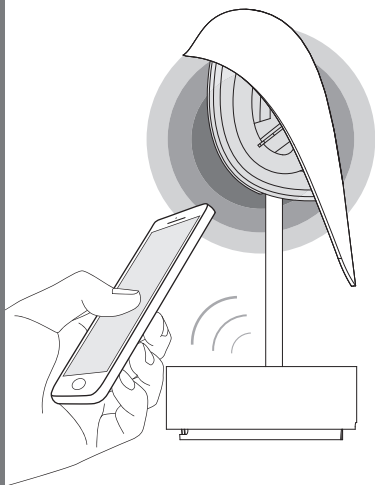

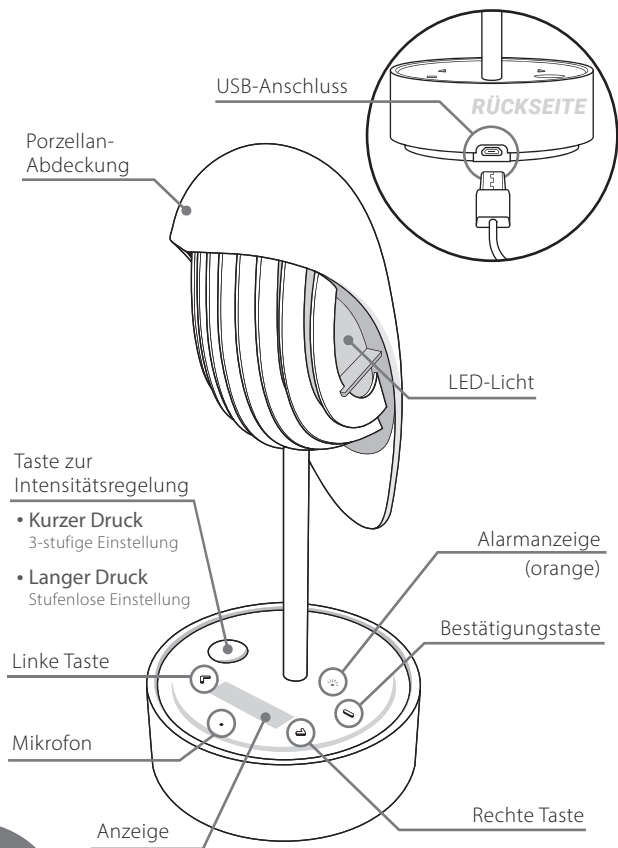

BEDIENUNG DISPLAY-MENÜ

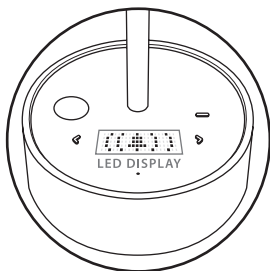

ALARM
Einstellungen



Alarm & Licht



Nur Alarm



SCHLAF
modus



countdown von
30 minutes



countdown von
60 minutes



LAUTSTÄRKE
regelung



Volumen 1



Volumen 7



NATURTON



Naturton 1



Naturton 2



Naturton 3

OPERATIONEN

Menüführung

Um das Display zu aktivieren, berühren Sie die Unterseite des Geräts, um die Uhrzeit anzuzeigen, und klicken Sie auf <oder>, um eine Einstellung auszuwählen. Drücken Sie zum Aktivieren die Bestätigungstaste

Aufwach-CHIRP, um die Zeit zu zeigen

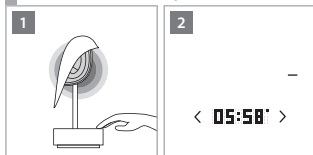

Klicken Sie auf die rechte oder linke Taste



Navigationsdetails

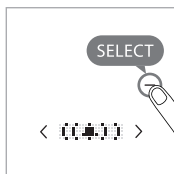

Sobald eine Variable ausgewählt ist, navigiert sie entweder automatisch zum nächsten Schritt oder kehrt zum allgemeinen Menü zurück.



Mit der runden Taste können Sie das Licht aufhellen und die Intensität einstellen.

Uhrzeit einstellen

Um die Uhrzeit einzustellen, wählen Sie zwischen einer 12-Stunden- und einer 24-Stunden-Uhrzeit und stellen Sie dann die Uhrzeit ein

Wählen Sie 12Std. / 24Std.

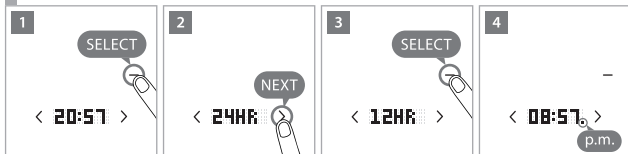

Zeit anpassen

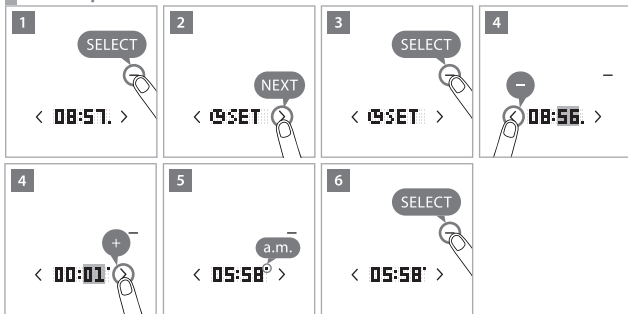

Bei Auswahl des 12-Stunden-Modus gibt die Position des Punkts an, ob die Uhrzeit vormittags oder nachmittags ist.

Alarm einstellen

Wählen Sie mit Licht- und Tonmodus oder Nur-Ton-Modus

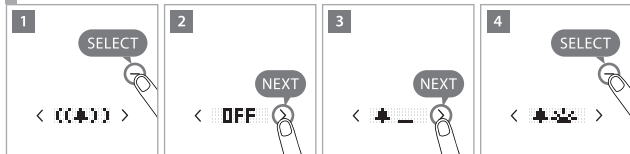

Passen Sie die Weckzeit an



Passen Sie die Alarmlautstärke an

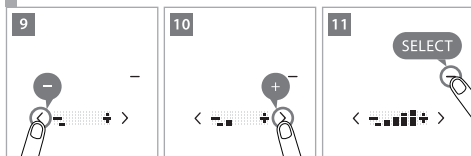

Die Alarmanzeige leuchtet orange, sobald die Alarminstellung abgeschlossen ist



Schlummerfunktion

Wenn der Weckton zur festgelegten Zeit abgespielt wird, können Sie auf eine beliebige Taste des Geräts tippen, um für eine Weile zu pausieren. Das Licht bleibt an, aber der Alarmton stoppt, nach 10 Minuten wird der Alarmton automatisch wiedergegeben.

10 Minuten lang warten

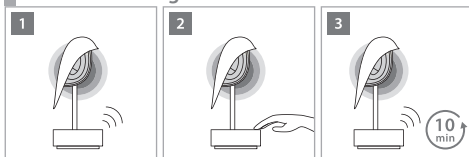

Alarm abschalten

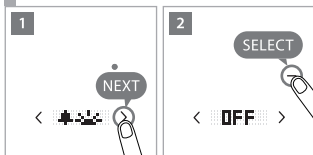

oder

Alarm abschalten

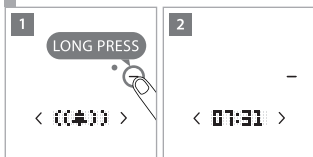

HINWEIS

Wenn Sie den Wecker nicht einschlafen oder ausschalten, wird der Wecker nach 15 Minuten automatisch ausgeschaltet.

Naturgeräusch abspielen

Wählen Sie einen Naturton, bestätigen Sie mit der Auswahltaste und der Ton wird weiter abgespielt.

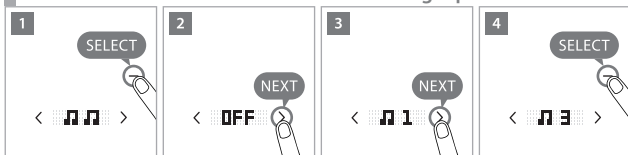

Stellen Sie die Lautstärke des Naturgeräuschs ein

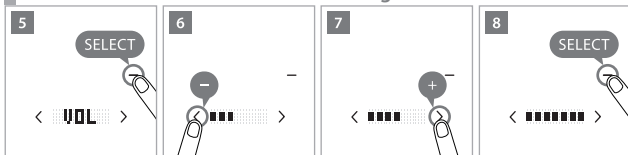

Geben Sie zum Ausschalten des Naturgeräuschs ein und wählen Sie „aus“.

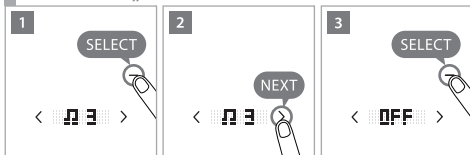

oder

Langer Druck

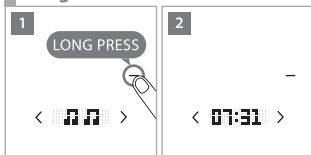

Schlafmodus

Um die Sleep-Funktion nutzen zu können, müssen Sie einen Timer auswählen.

- Drücken Sie auf den Ruhemodus und wählen Sie einen Countdown von 30 oder 60 Minuten. Drücken Sie anschließend auf Bestätigen.
- Nach 30 (oder 60) Minuten hört der Naturton auf und das Licht erlischt

Wählen Sie 30- oder 60-Minuten-Countdown

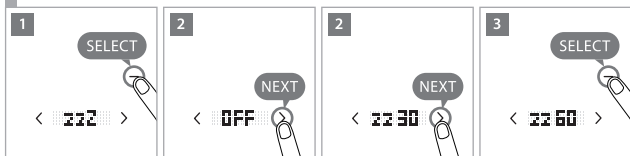

Synchronisieren Sie per Telefon App DAQIchirp

Zeit, Alarm und zusätzlicher Naturton können über die Telefon-App „DAQIchirp“ synchronisiert werden. Die ausgewählten Daten werden per Audioübertragung an DAQICONCEPT CHIRP übertragen.

HINWEIS

Eine erfolgreiche Übertragung kann nur garantiert werden, wenn der Lautsprecher des Telefons auf das Mikrofon von DAQICONCEPT CHIRP gerichtet ist.

Mikrofon

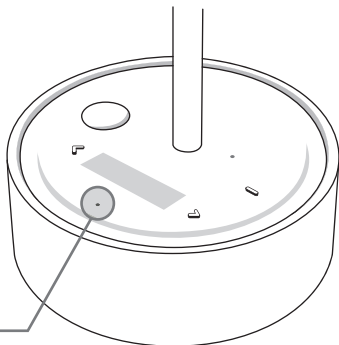

Find more information on : www.daqiconcept.com



GEBRUIKERSHANDLEIDING
NL – NEDERLANDS



WAARSCHUWING

- Gebruik een 1-poorts 5V1A/2A-USB-adapter.
- DAQICONCEPT CHIRP mag alleen geïnstalleerd en bediend worden in droge binnenruimtes. Installeer DAQICONCEPT CHIRP niet op plaatsen met een hoge luchtvochtigheid, bijv. in de badkamer.
- Raak nooit de plug en de kabel aan met natte handen vanwege het risico op een elektrische schok.
- Stel DAQICONCEPT CHIRP niet bloot aan extreme temperaturen, direct zonlicht, vocht, sterke trillingen of hoge mechanische spanning. De veilige bedrijfstemperatuur varieert tussen 50F/10° C en 95F/35° C.
- DAQICONCEPT CHIRP is gemaakt van stevig materiaal. Zorg dat het apparaat stevig gepositioneerd is om letsel of schade aan oppervlakken en voorwerpen door vallen te voorkomen. Laat de DAQICONCEPT CHIRP niet op de vloer vallen, sla er niet hard tegen en stel het niet bloot aan andere harde schokken.
- Het apparaat is niet bedoeld om gebruikt te worden door personen (waaronder kinderen) met beperkte fysieke, zintuigelijke of mentale vermogen of die ervaring en/of kennis missen, tenzij ze onder toezicht staan van iemand die verantwoordelijk is voor hun veiligheid, of die door deze persoon instructies hebben ontvangen over het gebruik van het apparaat.
- Dit is geen speelgoed. Kinderen moeten onder toezicht staan om te garanderen dat ze niet met de DAQICONCEPT CHIRP spelen.
- Kijk niet direct in de verlichte vogelbuik.
- Dek de DAQICONCEPT CHIRP niet af met een doek of plastic zak om schade door oververhitting te voorkomen.

OVERZICHT

DAQICONCEPT CHIRP is een alarmklok die decoratieve verlichting combineert met traditioneel vakmanschap. DAQICONCEPT CHIRP is een welkome afwisseling van de synthetische geluiden van een mobiel apparaat of een gewone wekker, en wekt u met zacht licht en de zalige geluiden van de natuur. Word verfrist en energiek wakker, klaar om elke nieuwe dag te beginnen.

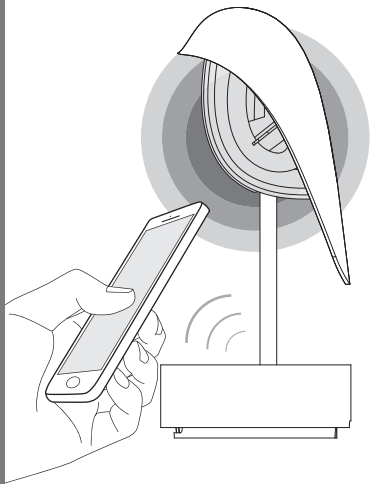

SPECIFICATIE

**Kleurtemperatuur
van de LED :** 2700K

Afmetingen :
210 (h) x 91 (b) x 91(l) mm

Gewicht :
400g

Materiaal:
porseleinen afdekking van
de vogel / marmeren basis /
metaal / plastic

Stroom via :
5V1A USB-oplader

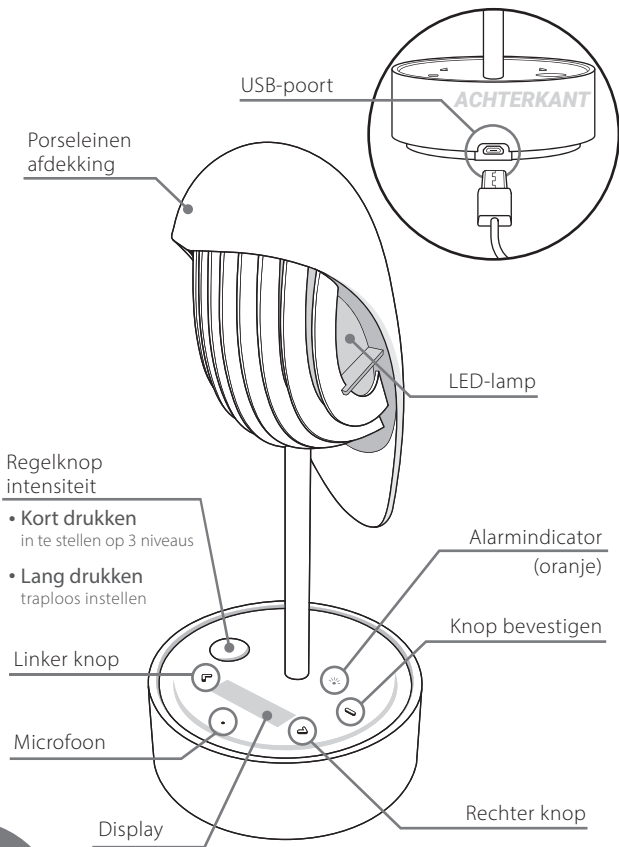

WEERGAVEMENU BEDIENING

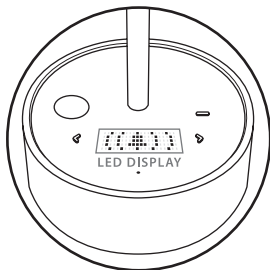

Alarmen
instellen



Alarm & licht



Alleen alarm



SLAAP
modus



30 minutes
aftellen



60 minutes
aftellen



VOLUME
regeling



Volume 1



Volume 7



NATUURGELUID



Natuurgeluid 1



Natuurgeluid 2



Natuurgeluid 3

BEDIENING

Navigatiemenu

Raak, om het display uit de slaapstand te halen, de basis aan om de tijd te tonen en klik op < of > om een instelling te selecteren, druk op de knop bevestigen om te laten werken.

Haal CHIRP uit de slaapstand om de tijd te tonen

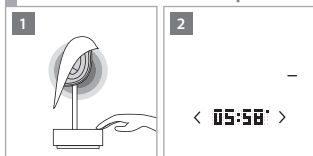

Klik op de linker of rechter knop



Details navigatie

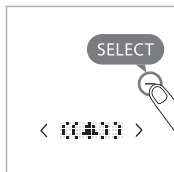

Zodra een variabele is geselecteerd, leidt hij je automatisch naar de volgende stap, of terug naar het algemene menu.



Met de ronde knop kun je het licht aanzetten of de intensiteit instellen.

Instellen kloktijd

Kies om de kloktijd in te stellen tussen een 12-uurs en een 24-uurs klok en pas daarna de tijd aan

Kies 12HR / 24HR

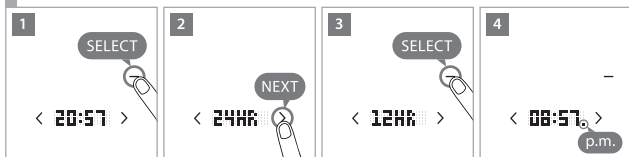

Pas de tijd aan

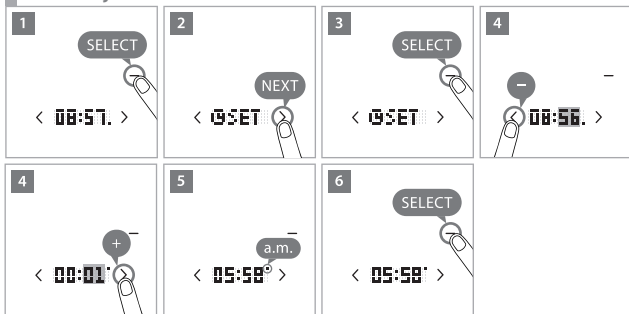

Wanneer de 12-uurs modus is gekozen, geeft de puntlocatie aan of de tijd a.m. of p.m. is.

Instellen alarm

Kies met-licht en geluidsmodus of de modus alleen geluid

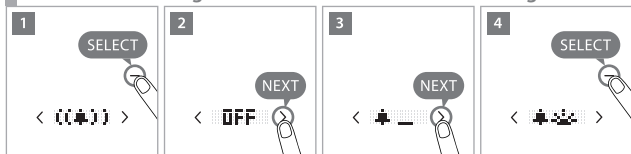

Stel de alarmtijd in



Stel het alarmvolume in

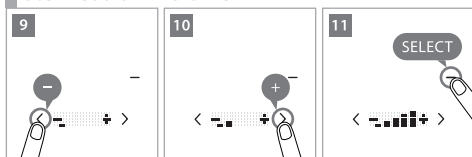

De alarmindicator licht oranje op zodra het instellen van het alarm klaar



Snooze

Wanneer het alarmgeluid wordt afgespeeld op de ingestelde tijd, kun je op een willekeurige knop van het apparaat tikken om nog even te doezelen. Het licht blijft aan, maar het alarmgeluid stopt en na 10 minuten wordt het alarmgeluid automatisch opnieuw afgespeeld.

10 minuten doezelen

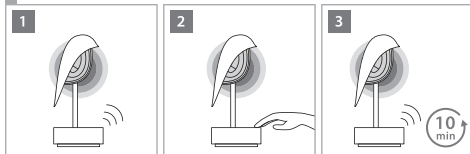

Schakel het alarm uit

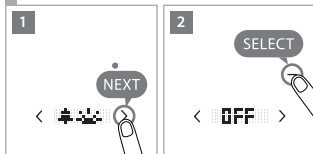

of

Schakel het alarm uit

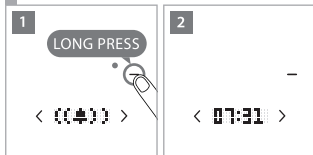

OPMERKING

Als je hem niet op snooze zet of het alarm uitschakelt, gaat het alarm automatisch na 15 minuten uit.

Natuurgeluid afspelen

Kies één natuurgeluid, bevestig met de keuzeknop en het geluid blijft spelen.

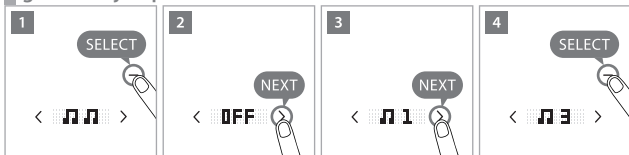

Pas het volume van het natuurgeluid aan

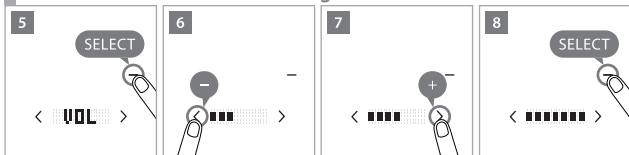

Ga om het natuurgeluid af te zetten naar en selecteer "uit"

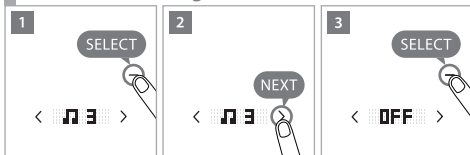

of

Lang drukken

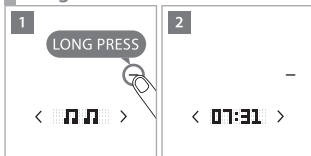

Slaapmodus

Om de slaapmodus te gebruiken moet je een timer selecteren.

- Druk op de slaapmodus en kies 30 of 60 minuten aftellen en druk daarna op bevestigen.
- Na 30 (of 60) minuten stopt het natuurgeluid en gaat het licht uit

Selecteer 30 of 60 minuten aftellen

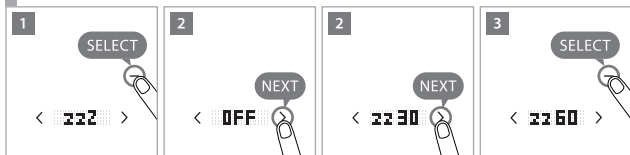

Synchroniseren met de telefoon-app DAQIchirp

Tijd, alarm en extra natuurgeluid kunnen worden gesynchroniseerd met de telefoon-app “DAQIchirp”. De geselecteerde details worden overgebracht via audiotransmissie naar DAQICONCEPT CHIRP.

OPMERKING

Een succesvolle transmissie kan alleen worden gegarandeerd wanneer de luidspreker van de telefoon naar de microfoon van de DAQICONCEPT CHIRP is gericht.

Microfoon

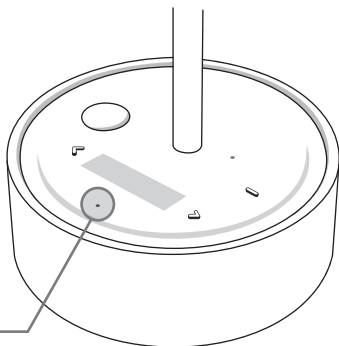

Find more information on : www.daqiconcept.com



MANUALE UTENTE
IT – ITALIANO



ATTENZIONE

- Utilizzare un alimentatore USB 5V1A/2A da 1 porta.
- DAQICONCEPT CHIRP deve essere installato e utilizzato all'interno di ambienti asciutti. Non installare DAQICONCEPT CHIRP in ambienti con un elevato livello di umidità, come per esempio in bagno.
- Non toccare la spina e il cavo con le mani umide a causa del rischio di shock elettrico.
- Non esporre DAQICONCEPT CHIRP a temperature estreme, luce diretta del sole, umidità, forti vibrazioni ed elevato stress meccanico. La temperatura operativa di sicurezza è compresa tra 50F/10° C e 95F/35° C.
- DAQICONCEPT CHIRP è realizzato in materiale solido. Assicurarsi che il dispositivo sia posizionato in modo sicuro per scongiurare ferimenti o danni alle superfici o agli oggetti come conseguenza della sua caduta. Non lasciar cadere DAQICONCEPT CHIRP a terra, né colpirlo con forza o esporlo ad altri urti violenti.
- Questo dispositivo non è stato concepito per essere usato da persone (tra cui bambini) con capacità fisiche, sensoriali o mentali limitate, o prive di esperienza e/o conoscenza, se non sotto la supervisione di una persona responsabile della loro sicurezza o dopo aver ricevuto istruzioni sull'uso del dispositivo da un'altra persona.
- Non è un giocattolo. I bambini devono avere la supervisione di un adulto che controlli che non utilizzino DAQICONCEPT CHIRP come un giocattolo.
- Non guardare direttamente la pancia luminosa dell'uccellino.
- Non coprire DAQICONCEPT CHIRP con un panno né con un sacchetto di plastica per evitare che, surriscaldandosi, si danneggi.

PANORAMICA

DAQICONCEPT CHIRP è una sveglia che unisce la decorazione luminosa all'artigianato tradizionale. Diversamente dal suono sintetico e impersonale della suoneria di un telefono o di una sveglia tradizionale, DAQICONCEPT CHIRP ti dà il buongiorno con una luce delicata e il suono armonioso della natura. Ti sveglierai ricaricato, pieno di energia e pronto a iniziare la giornata in modo nuovo.

SPECIFICHE

Temperatura di colore del LED : 2700K

Dimensioni :
210 (h) x 91 (w) x 91 (l) mm

Peso :
400g

Materiale:
porcellana di copertura dell'uccellino /
base in marmo / metallo /
plastica

Alimentazione :
alimentatore USB 5V1A

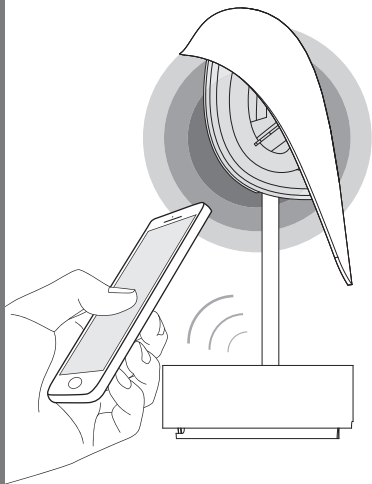

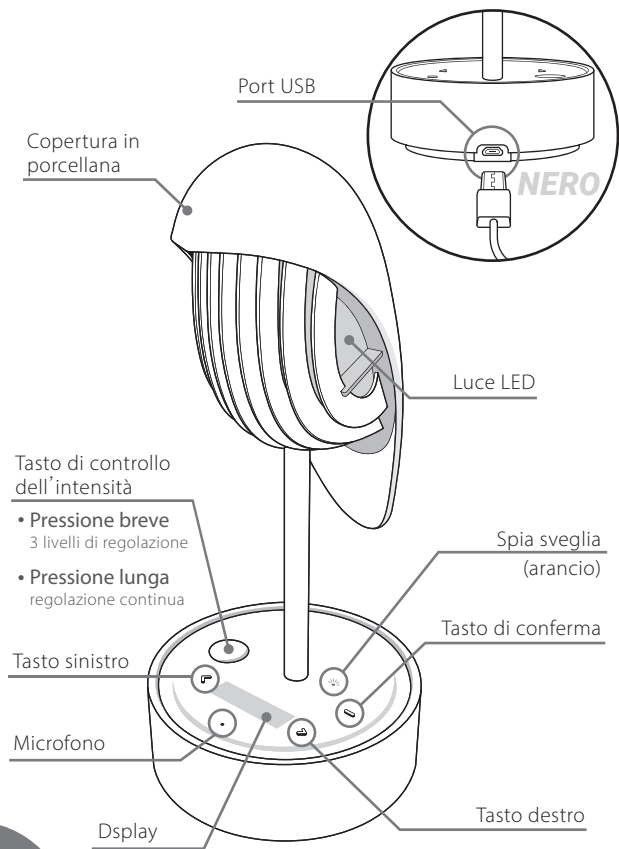

MENU OPERATIVO

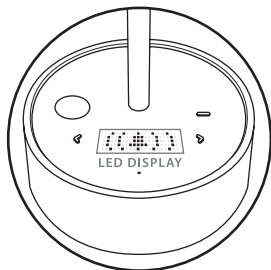

Impostazione
sveglia



Allarme sonoro
& luminoso



Solo allarme
sonoro



Modalità
SLEEP



Conto alla
rovescia
30 minuti



Conto alla
rovescia
60 minuti



REGOLAZIONE
VOLUME



Volume 1



Volume 7



SUONO
NATURA



Suono natura 1



Suono natura 2



Suono natura 3

FUNZIONAMENTO

Menu di navigazione

Per attivare il display, toccare il tasto del dispositivo per visualizzare l'ora, quindi fare clic < oppure > selezionare una modalità, premere il tasto di conferma per attivarla

Attivare CHIRP per visualizzare l'ora

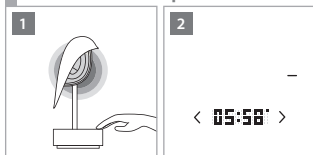

Fare clic sul tasto sinistro



Descrizione della navigazione

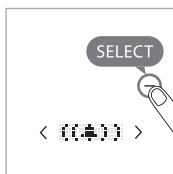

Una volta selezionata un'opzione, questa permetterà di andare automaticamente al passaggio successivo oppure di ritornare al menu principale.

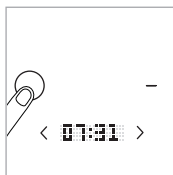

Il tasto circolare permette di accendere la luce e regolare l'intensità.

Impostazione dell'orologio

Per impostare l'orologio, selezionare tra una visualizzazione a 12 o 24 ore, quindi regolare l'ora.

Selezionare 12HR/ 24HR

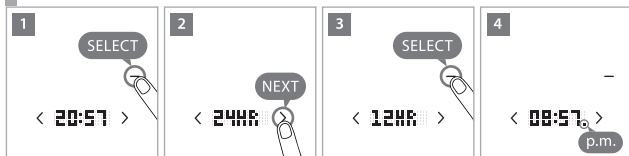

Regolare l'ora

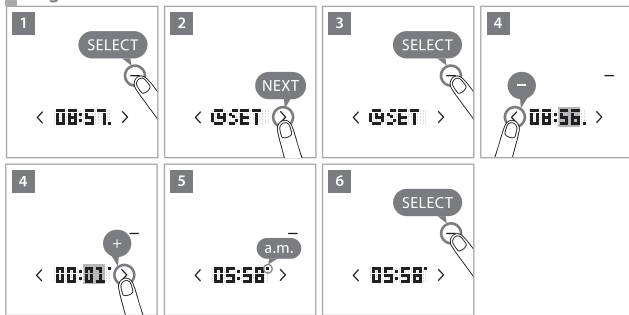

Selezionando la modalità 12h, l'ubicazione del punto indica se si tratta di a.m. o p.m.

Impostazione sveglia

Selezionare la modalità luce + suono oppure solo suono

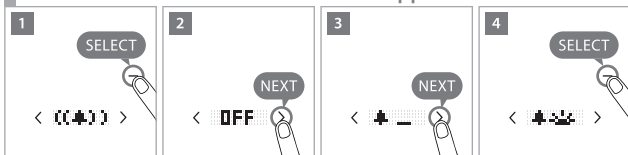

Regolare l'ora della sveglia



Regolare il volume della sveglia

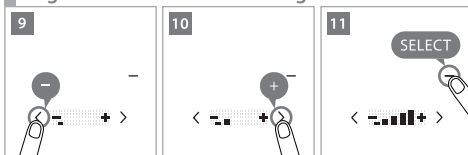

La spia arancione della sveglia è accesa quando la sveglia è impostata



Funzione "Snooze" (pausa)

Quando la sveglia suona all'ora stabilita è possibile, premendo un tasto qualsiasi del dispositivo, posporla per un dato intervallo di tempo. La luce rimane accesa, ma il suono si interrompe. A distanza di 10 minuti, suonerà di nuovo.

Funzione "Snooze" 10 minuti

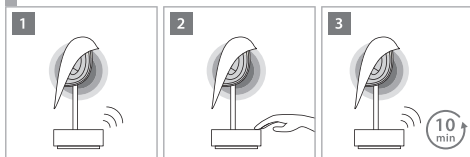

Spegnimento della sveglia

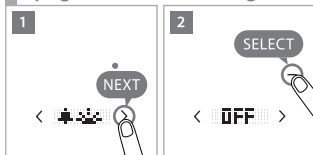

oppure

Spegnimento della sveglia

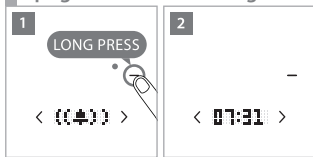

AVVERTIMENTO

Se la sveglia non viene messa in pausa o spenta, questa si spegnerà automaticamente dopo 15 minuti.

Suono Natura

Scegliere uno dei suoni natura disponibili, confermare con il tasto di selezione per riprodurlo.

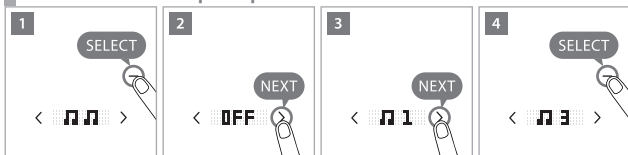

Regolare il volume del suono natura

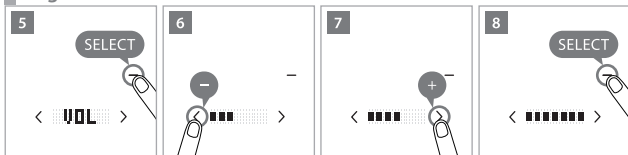

Per spegnere il suono natura, inserire **1 1**, e selezionare "off"



oppure

Pressione lunga

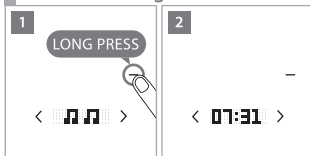

Modalità sleep

Per utilizzare la funzione sleep, è necessario impostare un timer.

- Premere la modalità sleep e selezionare il conto alla rovescia da 30 o 60 minuti, quindi premere conferma.
- Dopo 30 (o 60) minuti, il suono natura si interromperà, così come la luce

Selezionare il conto alla rovescia da 30 o 60 minuti

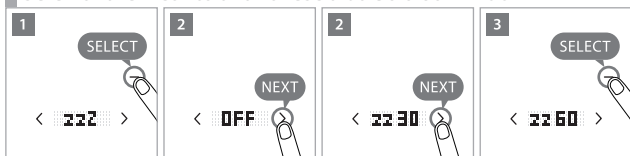

Sincronizzare con il telefono tramite l'App DAQIChirp

L'ora, la sveglia e altri suono natura possono essere sincronizzati con il telefono tramite l'App "DAQIChirp". I dati selezionati verranno trasmessi tramite trasmissione audio con DAQICONCEPT CHIRP.

N.B.

è possibile svolgere questa operazione solo se il microfono del telefono è rivolto verso il microfono di DAQICONCEPT CHIRP.

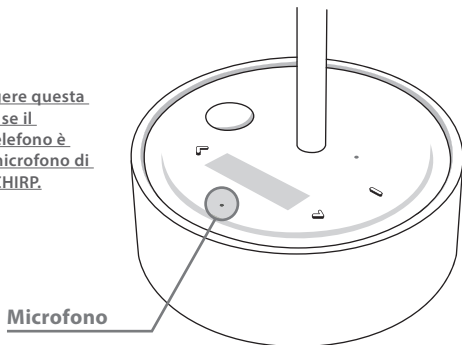

Find more information on : www.daqiconcept.com



MANUAL DEL USUARIO
ES – ESPAÑOL



WAARSCHUWING

- Use un adaptador de USB 5V1A / 2A de 1 puerto.
- DAQICONCEPT CHIRP debe ser instalado e utilizado en espacios interiores secos. No instale DAQICONCEPT CHIRP en lugares con altos niveles de humedad, p.j. el baño.
- No toque nunca el enchufe y el cable con las manos mojadas debido al riesgo de choque eléctrico.
- No expongas DAQICONCEPT CHIRP a temperaturas extremas, tomar sol directo, humedad, vibraciones fuertes o alta tensión mecánica. El rango de la temperatura de operación segura está entre 50F/10° C y 95F/35° C.
- DAQICONCEPT CHIRP está hecho de material sólido. Verifique que el dispositivo está bien apoyado para evitar lesiones o daños a superficies y objetos por la caída. No dejes caer DAQICONCEPT CHIRP en el piso, pegado fuerte o lo exponga a otros golpes fuertes.
- No recomendado el uso por personas (incluidos niños) con capacidades físicas, sensoriales o mentales restringidas, o falta de experiencia y/o conocimiento, salvo supervisados por una persona responsable de su seguridad o ha recibido instrucciones de manejo del dispositivo.
- No es un juguete. Los niños deben ser supervisados para asegurarse de que no jueguen con DAQICONCEPT CHIRP.
- No fijar la vista directamente a la luz situada en el pecho del pájaro .
- No cubras DAQICONCEPT CHIRP con tela o bolsa plástica para evitar daños por calentamiento excesivo.

VISION GENERAL

DAQICONCEPT CHIRP es un reloj despertador que está combinado la iluminación decorativa con la artesanía tradicional. Una bienvenida de sonidos sintetizados de un dispositivo móvil o al despertador normal, DAQICONCEPT CHIRP le despierta con una luz suave y los sonidos maravillosos de la naturaleza. Despierta con una fresca sensación, lleno de energía y listo para comenzar un nuevo día.

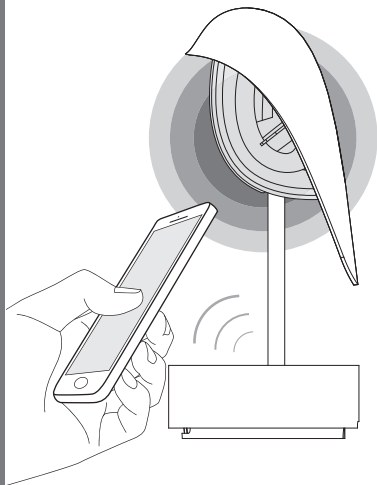

ESPECIFICACION

Temperatura de Color de LED : 2700K

Dimensión :
210 (h) x 91 (w) x 91(l) mm

Peso :
400g

Material :
cubierta de pájaro de
porcelana /
base de mármol / metal /
plástico

Potencia por :
Cargador de USB 5V1A

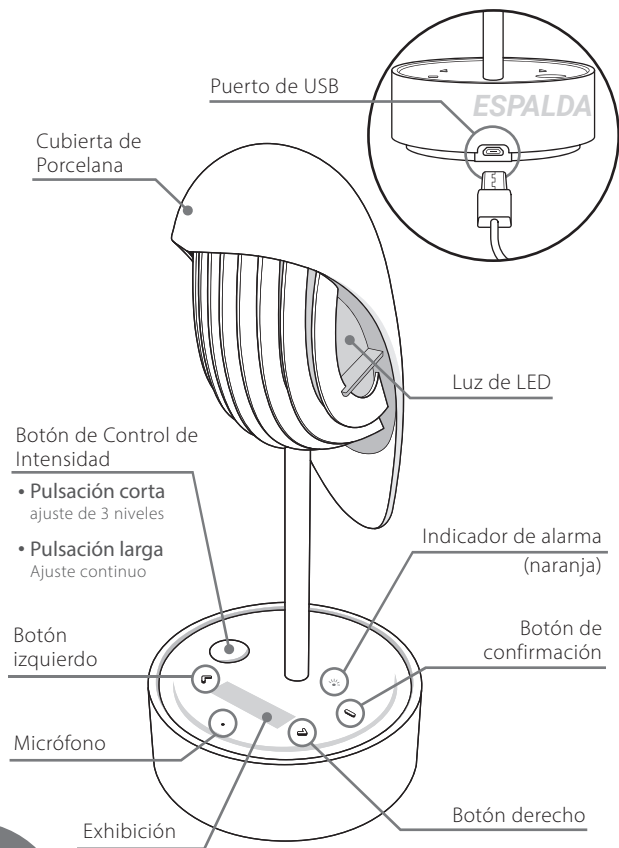

MENÚ

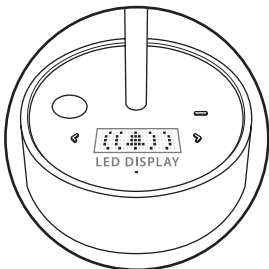

Ajuste de
alarma



Alarma y luz



Sólo alarma



Modo de
DORMIR



Cuenta
regresiva de
30 minutos



Cuenta
regresiva de
60 minutos



CONTROL
DEL
VOLUMEN



Volumen 1



Volumen 7



SONIDO DE LA
NATURALEZA



Sonido de la
naturaleza 1



Sonido de la
naturaleza 2



Sonido de la
naturaleza 3

OPERACIÓN

Menú de navegación

Para activar el menú, presione el botón del dispositivo para mostrar la hora, y haga clic en <or> para seleccionar un ajuste, apriete el botón de confirmación para confirmar

Despierta CHIRP para mostrar la hora

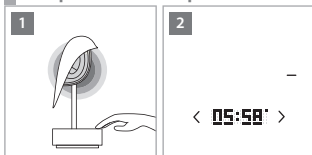

Haga clic en el botón derecho o izquierdo



Detalles de navegación

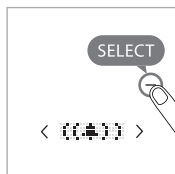

Una vez seleccionado el variable, le lleva automáticamente al siguiente paso o retrocede al menú general.



El botón redondo le permite iluminar la luz y ajustar la intensidad.

Ajuste del tiempo de Reloj

Para ajustar el tiempo del reloj, elija entre un reloj de 12 horas y 24 horas y luego ajuste el tiempo

Elija 12HR/ 24HR

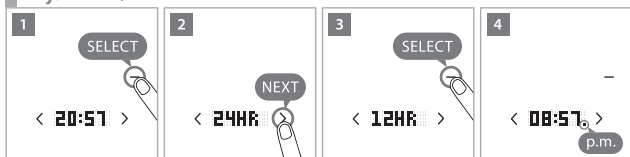

Ajuste el tiempo

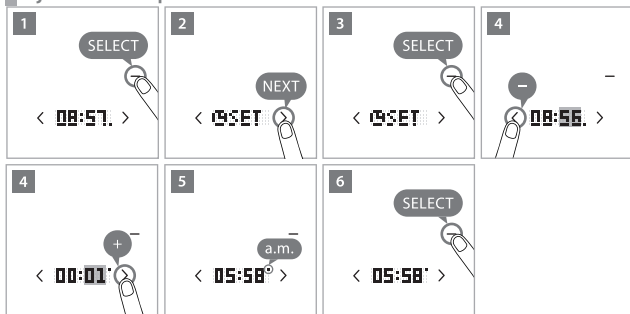

Cuando está seleccionado el modo de 12 horas, la ubicación del punto indicaría si la hora es de a.m. o p.m.

Ajuste de Alarma

Elija el modo de luz y sonido o modo de sonido solo

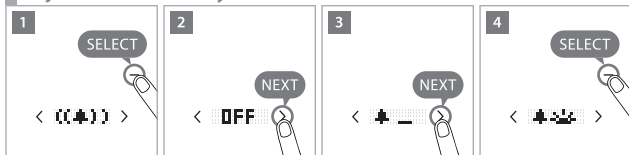

Ajuste el tiempo de alarma



Ajuste el volumen de alarma

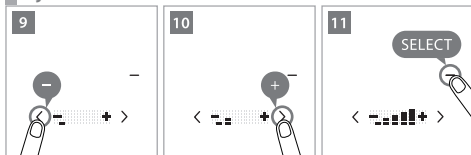

Iluminado el indicador de alarma en naranja una vez terminado el ajuste de alarma



Posponer

Cuando se está reproduciendo el sonido de la alarma a la hora seleccionada, puede tocar cualquier botón del dispositivo para retrasarlo. Permaneciendo encendida la luz, deteniendo el sonido 10 minutos, después será sonará de nuevo automáticamente.

Posponer 10 minutos

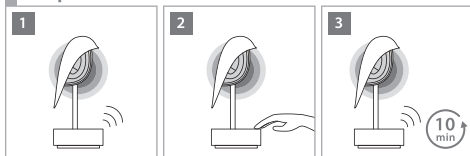

Apagar la alarma

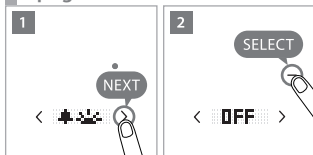

o

Apagar la alarma

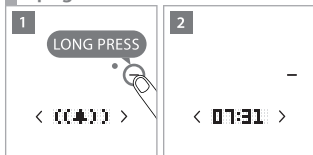

AVISO

Si no posponga o apaga la alarma, la alarma se apagará automáticamente luego de 15 minutos.

Reproducir sonido de la naturaleza

Elija un sonido de la naturaleza, confirme con el botón de selección y el sonido mantiene reproduciendo.

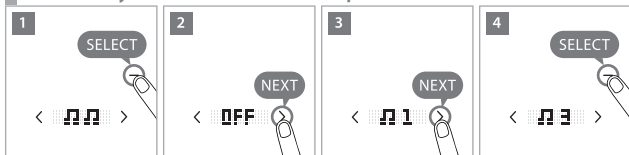

Ajuste del sonido de la naturaleza

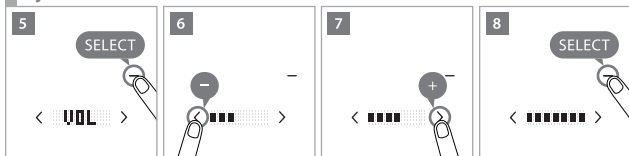

Para apagar el sonido de la naturaleza, entre y escoger "off"

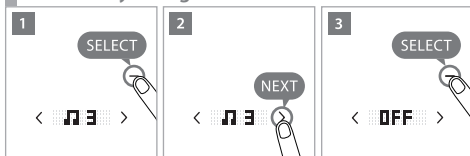

o

Pulsación larga

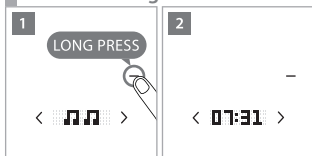

Modo de dormir

Para usar la función de dormir, debe seleccionar una hora.

- Seleccione el modo de dormir y elija la cuenta regresiva de 30 o 60 minutos, luego presione de nuevo para confirmar.
- Después de 30 (o 60) minutos, el sonido de la naturaleza natural se suspenderá y la luz se apagará

Seleccionar 30 o 60 minutos de cuenta regresiva

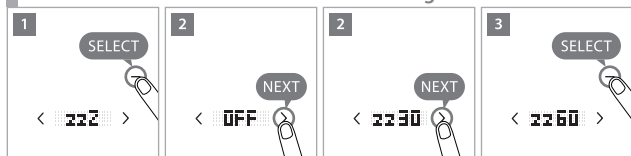

Sincronizar por App DAQIchirp de teléfono

El tiempo, la alarma y el sonido adicional de la naturaleza podrían ser sincronizados a través de App DAQIchirp de teléfono. Los datos seleccionados será transmitido mediante la transmisión de audio a DAQICONCEPT CHIRP.

AVISO

La transmisión será exitosa mientras el altavoz del teléfono está frente al micrófono de DAQICONCEPT CHIRP.

Micrófono

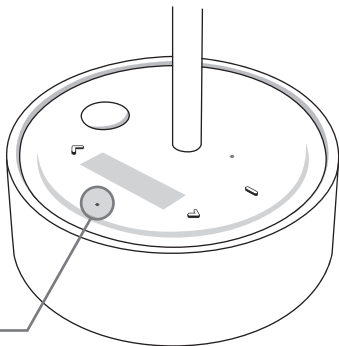

Find more information on : www.daqiconcept.com



MANUEL D'UTILISATEUR
FR – FRANÇAIS



- Utiliser un adaptateur USB 1 port 5V1A / 2A
- DAQICONCEPT CHIRP doit être installé et utilisé uniquement dans des espaces intérieurs secs et n'installez pas DAQICONCEPT CHIRP dans des endroits très humides, par exemple dans la salle de bain.
- Ne touchez jamais ni la fiche ni le câble avec les mains mouillées en raison du risque de choc électrique.
- N'exposez pas DAQICONCEPT CHIRP à des températures extrêmes, à la lumière directe du soleil, à l'humidité, à de fortes vibrations ou à des contraintes mécaniques élevées.
- DAQICONCEPT CHIRP est fabriqué en matériau solide. Assurez-vous que que l'appareil est correctement positionné pour éviter les blessures et les dommages aux surfaces et aux objets suite à une chute. Ne laissez pas tomber DAQICONCEPT CHIRP sur le sol, ne pas le frapper fort et ne pas l'exposer à d'autres chocs violents.
- Cet appareil n'est pas destiné à être utilisé par des personnes (y compris les enfants) ayant des capacités physiques, sensorielles ou mentales limitées, ou manquant d'expérience et / ou de connaissances, à moins que la personne responsable de leur sécurité les supervise ou leur fournisse des directives d'utilisation.
- Ce n'est pas un jouet. Les enfants doivent être surveillés pour s'assurer qu'ils ne jouent pas avec DAQICONCEPT CHIRP.
- Ne regardez pas directement le ventre de l'oiseau éclairé.
- Ne couvrez pas DAQICONCEPT CHIRP avec un chiffon ou un sac en plastique pour éviter les dégâts de surchauffe

CONCEPTION GENERALE

DAQICONCEPT CHIRP est une réveil qui combine une lampe décorative avec un travail artisanal. DAQICONCEPT CHIRP vous réveille avec une lumière douce et les sons enchantés de la nature. Réveillez-vous en vous sentant rafraîchi, énergisé et prêt à commencer chaque nouvelle journée.

SPÉCIFICATION

LED Température de couleur : 2700K

Dimension:
210 (h) x 91 (w) x 91(l) mm

Poids :
400g

Matériau:
couverture d'oiseau en porcelaine / base en marbre / métal / plastique

Alimenté par :
Chargeur USB 5V1A

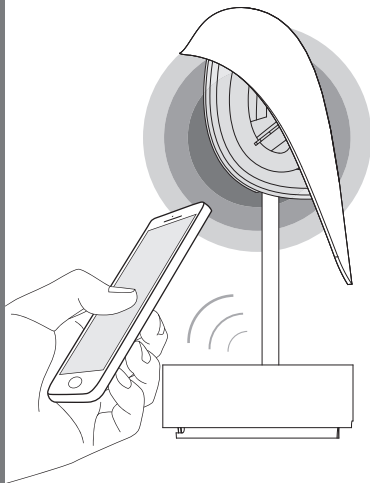

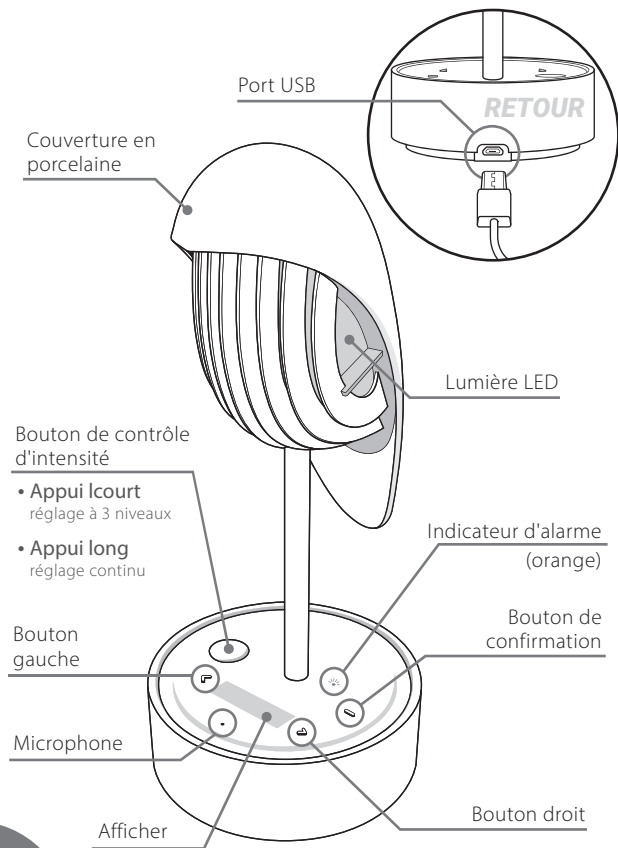

MENU D'AFFICHAGE DES OPÉRATIONS

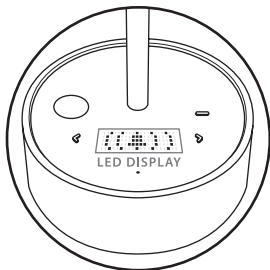

Réglage de
l'alarme



Alarme et
lumière



Alarme
seulement



Mode
sommeil



Compte à
rebours de
30 minutes



Compte à
rebours de
60 minutes



CONTRÔLE DU
VOLUME



Volume 1



Volume 7



SON DE LA
NATURE



Son de la
nature 1



Son de la
nature 2



Son de la
nature 3

OPÉRATIONS

Navigation par menu

Pour réactiver l'affichage, touchez le bas de l'appareil pour afficher l'heure, puis cliquez sur <ou> pour sélectionner un paramètre, appuyez sur le bouton de confirmation pour valider.

Réveillez le CHIRP (pépiement) pour afficher l'heure

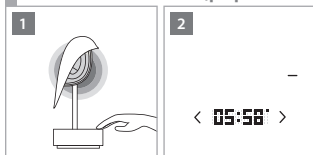

Cliquez sur le bouton droit ou gauche



Détails de navigation

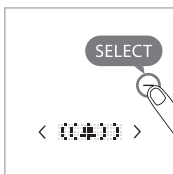

Une fois qu'une variable est sélectionnée, elle vous dirige automatiquement vers l'étape suivante ou revient au menu général.



Le bouton rond vous permet d'éclairer la lumière et de régler l'intensité

Réglage de l'heure

Pour régler l'heure, choisissez une horloge de 12 heures ou 24 heures, puis ajuster l'heure

Choisissez 12HR / 24HR

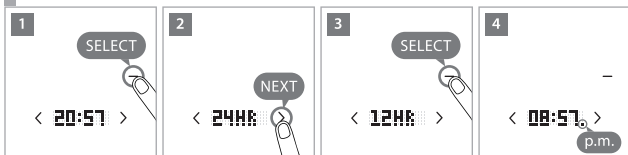

Ajustez le temps

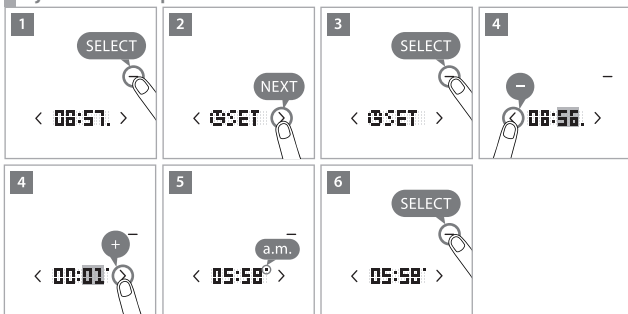

Lorsque vous avez choisi le mode de 12 heures, l'emplacement du point indique si le CHIRP est réglé en format AM ou PM.

Réglage de l'alarme

Choisissez le mode son-lumière ou le mode son seul

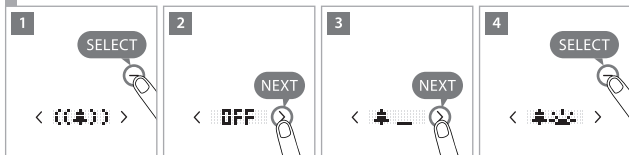

Ajustez l'heure de l'alarme



Ajustez le volume de l'alarme

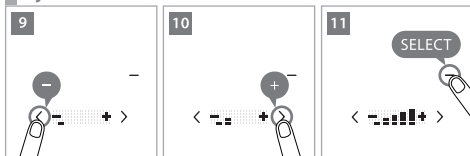

L'indicateur d'alarme s'allume en orange une fois le réglage de l'alarme terminé



Sommeiller

Lorsque le son de l'alarme retentit à l'heure définie, vous pouvez appuyer sur n'importe quel bouton de l'appareil pour le répéter. La lumière reste allumée, mais le son de l'alarme s'arrête. Après 10 minutes, le son de l'alarme sera automatiquement reproduit.

Sommeillez pendant 10 minutes

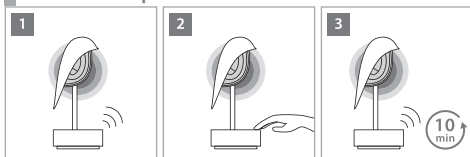

Éteignez l'alarme

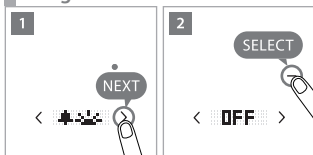

ou

Éteignez l'alarme

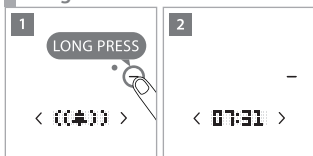

REMARQUE

Si vous ne sommeillez ni éteignez l'alarme, ce dernier s'éteindra automatiquement au bout de 15 minutes.

Jouez le son de la nature

Choisissez un son de la nature, confirmez avec le bouton de sélection et le son continuera de jouer.

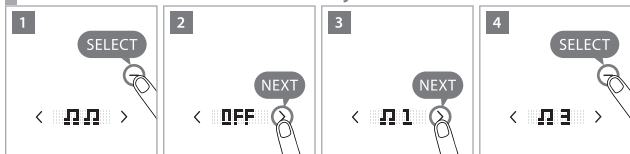

Ajustez le volume du son de la nature

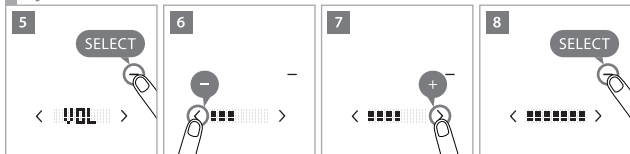

Pour éteindre le son de la nature, entrez et sélectionnez «off»

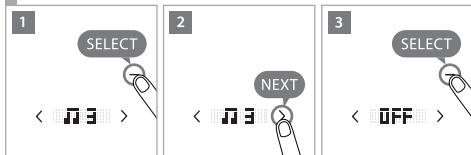

ou

Appui long

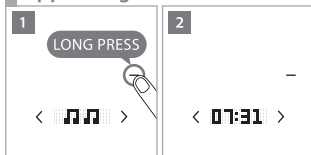

Mode de sommeil

Pour utiliser la fonction de sommeil, vous devez sélectionner une minuterie.

- Appuyez sur le mode de sommeil et choisir un compte à rebours de 30 ou de 60 minutes, puis appuyer sur confirmer.
- Après 30 (ou 60) minutes, le son de la nature s'arrête et la lumière s'éteint. così come la luce

Sélectionnez le compte à rebours de 30 ou de 60 minutes

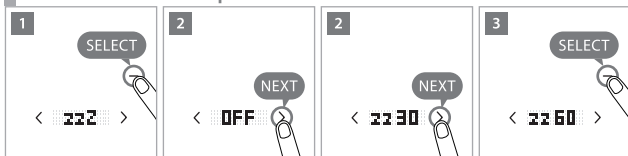

Synchronisez par l'application mobile daqichirp

L'application téléphonique «DAQIChirp» vous permet de synchroniser l'heure, les alarmes et des sons de la nature supplémentaires. Les données sélectionnées sont transmises via une transmission audio à DAQICONCEPT CHIRP.

REMARQUE

Une transmission réussie ne peut être garantie que lorsque le haut-parleur du téléphone est en face du microphone de DAQICONCEPT CHIRP.

Microphone

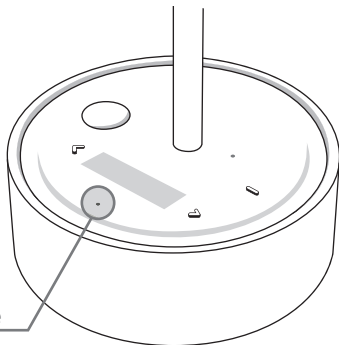

Find more information on : www.daqiconcept.com



www.daqiconcept.com

DAQI CONCEPT INC.

Made in Taiwan / ©All rights reserved